

Hydrostatic Head Level Switches

DF Series

The DF series are diaphragm-operated hydrostatic head pressure level switches. A pressure sensitive diaphragm operates a snap-switch that can be wired directly to electric pilot circuits to control pumps at predetermined levels. Typical application is to start and stop electric driven pump(s) to maintain tank levels. It is also applicable to engine-driven pumps.

The nitrile sensing diaphragm is impervious to most liquids and is sensitive enough to control levels with 1/4 in. (6 mm) repeatability. See model descriptions for limits of switch trip point adjust ability. Materials include aluminum body, glass-filled nylon bottom plate and a special alloy leaf snap switch as standard.

This simple level switch is highly reliable and can be worked into almost any new or existing system without major modification or special tools.

The DF755 is suitable for atmospheric tanks in a non-hazardous area. The SPDT snap-switch for the DF755 is preset for a 4 in. (102 mm) differential in liquid level.



All trademarks and service marks used in this document are the property of their respective owners.

Specifications

Snap Switch Ratings

SPDT

15 A @ 125, 250 VAC

Case/Lid: Aluminum

Bottom Plate: Glass-filled Nylon

Process Connection: 1 NPT

Maximum Pressure Rating: 25 psi (172 kPa [1.72 Bar])

Conduit Connection (electrical): 1/2 NPT

RoHs Compliant

Dimensions

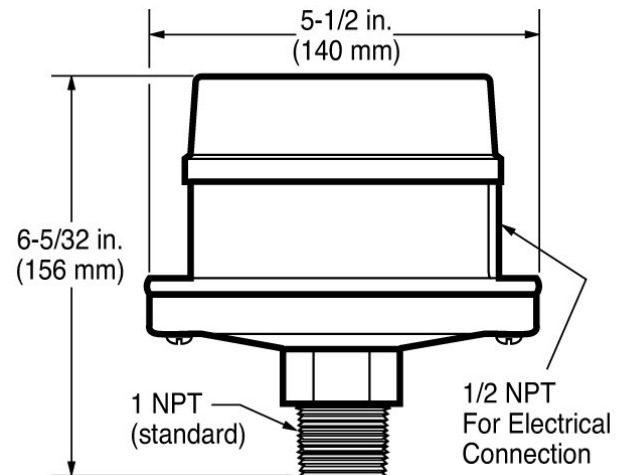

Applications

- Saltwater Disposal Systems
- Cooling Towers
- Crude Oil Tanks
- Waterflood Systems
- Diesel Day Tanks
- Sumps

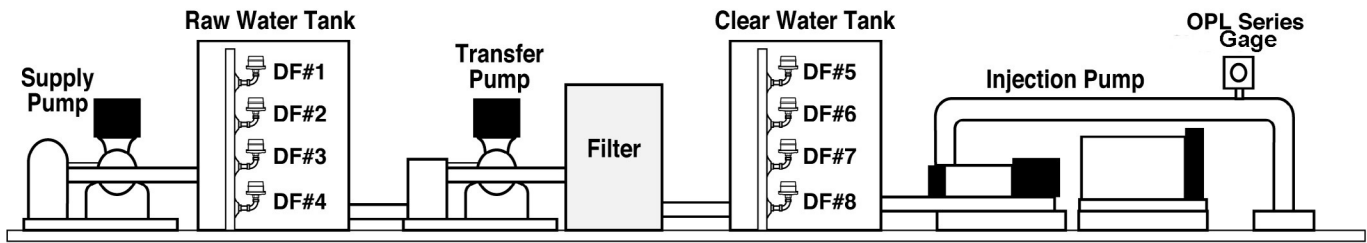

Typical Water Flood Control System

The diagram above displays eight DF Series switches installed on a Raw Water tank and a Clear Water tank. When raw water rises to predetermined level, DF#1 stops the supply pump. As the tank level falls below the predetermined level, DF#2 starts the supply pump. If the tank level continues to fall, DF#3 initiates shutdown of the supply pump. DF#4 stops the transfer pump before the raw water tank is completely pumped out. When clear water reaches the predetermined level, DF#5 stops the transfer pump. As the tank level falls to a predetermined low level, DF#6 starts the transfer pump. If the tank level continues to fall due to the failure of the filters section, DF#7 initiates shutdown of the transfer pump. (DF755 located at this level will also operate backwash equipment). DF#8 stops the injection pump before the tank pumps completely out. An OPL Series Pressure gage stops injection pump when pressure reaches predetermined high or low pressure

Typical Tank Mounting Methods (DF755)

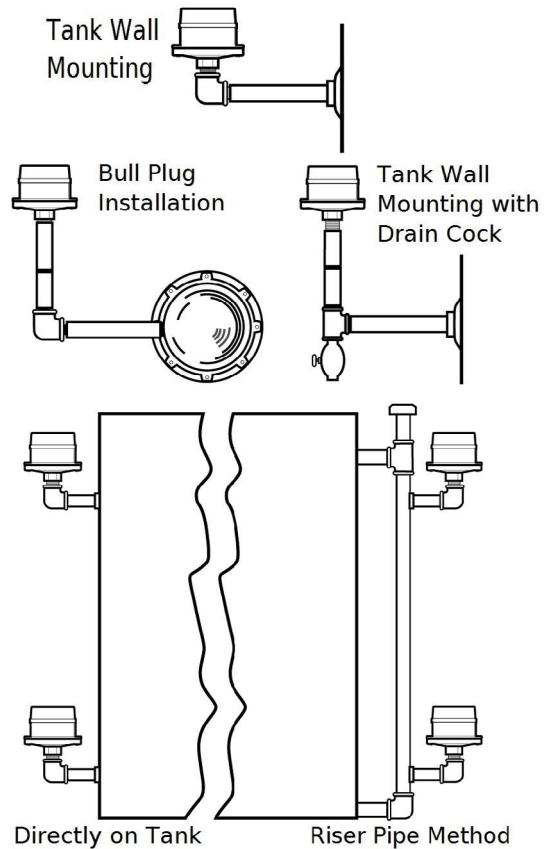

Typical Wiring

Starts at Low Level, Stops at High

Start motor when predetermined low level is reached and stops when high level is reached. Keeps tank level within selected limits. Motor starter equipped with H.O.A.

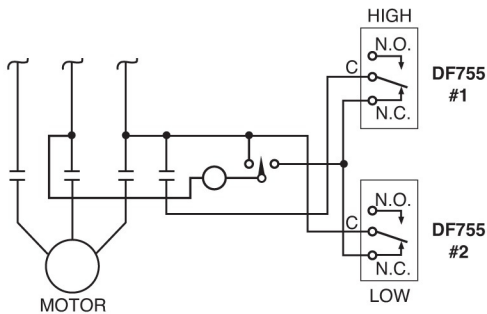

Starts at High Level, Stops at Low

Start motor when predetermined high level is reached and stops when low level is reached. Motor starter equipped with H.O.A.

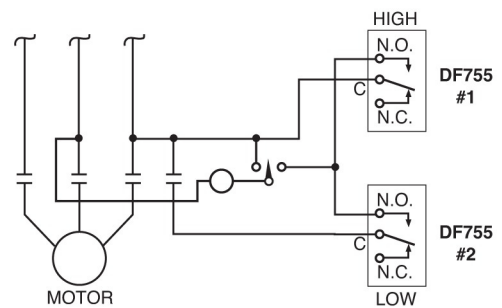

Single Magneto Shutdown

Shut down single ignition engine when fluid reaches low level. Simple wiring of magneto to N.O. switch terminal will shut down engine at predetermined high level.

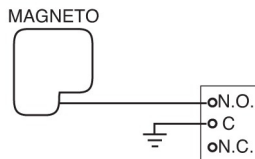

Dual Magneto Shutdown

Shut down dual magneto engines using FW Murphy MS2120 Magnetic Switch. Diagram shows hookup for low level shutdown. Simple wiring changes and mounting locations are necessary for high level shutdowns.

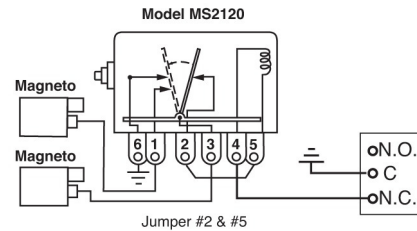

Basic Operation

As the liquid level rises, hydrostatic head pressure is applied to the diaphragm **A**. The diaphragm is forced upward forcing the actuator arm **B** to activate the snap switch **C**.

Model DF755 is factory set and operates at approximately 2 in. (51 mm) and 6 in. (152 mm) above the level at which the diaphragm is mounted. The trip point(s) for Model DF757 are adjustable between 2 in. (51 mm) and 110 in. (2794 mm) for high and low (make/break) operation by knobs, **D**.

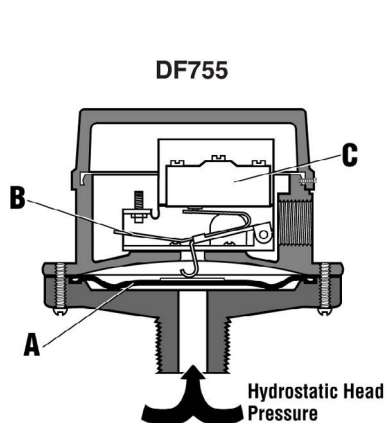

The SPDT snap-switch for the DF755 is preset for a 4 in. (102 mm) differential in liquid level.

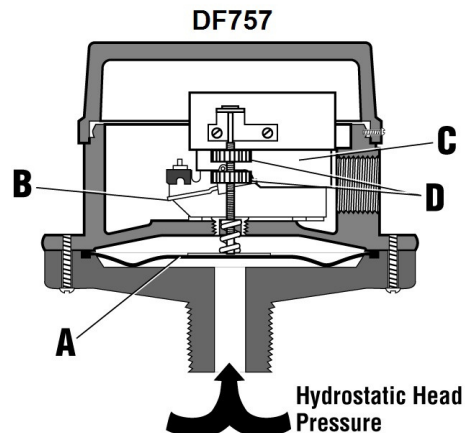

For reference only, DF757 is not available. The DF757 trip point is adjustable over a 108 in. (2743 mm) differential.

How to Order

Part Number	Model and Description	Notes
15700001	DF755: Hydrostatic head level switch, SPDT snap-switch	DF Series switch
15700037 obsolete	DF757: Hydrostatic head level switch, adjustable trip point	
15000123	Diaphragm Repair Kit	DF Series service part
15000121	Snap switch and insulator assembly	DF755 Series service part
15000122	Snap switch, insulator and movement assembly	
15000174 obsolete	Snap switch and bracket assembly	DF757 Series service part

Approximate Shipping Weight and Dimensions		
Model	Weight	Weight Dimension
DF755	3 lb. (1.4 kg)	6-1/4 x 6-1/4 x 6-1/4 in. (159 x 159 x 159 mm)
DF757 obsolete		



CONTACT

✉ sales@rajkotmarinellc.ae
 ☎ +971 6 7487580
 🌐 www.rajkotmarine.com

RAJKOT MARINE LLC

*Jerf Industrial Area 1,
 P.O Box 5861
 Ajman, UAE*

